

Smart silence lock AX061 (with access control) operating instructions

Electric property:

Input voltage: DC12V

Standby current(ISTB): 60mA

Read Range: 5~10mm

ID card volume: 2000 sets

Remotecontrolled distance: within 7m

Wireless remote control distance: within 50m

Wiring method of Circuit board

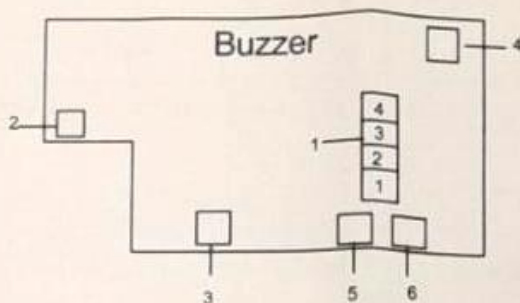

1. Power

1.1 Power positive input DC 12V

1.2 Power negative output GND

1.3 unlocking input

1.4 unlocking output

2. Door Contact Input

3. Motor Output

4. The indicator light output of cylinder

5. The induction coil of cylinder

6. The induction coil of inside cylinder

Simple method of using

1. Access 12V power (positive 12 V, negative GND), confirm lock electricity

2. Add user card

2.1 read the Management Card on the induction coil, green indicator light is flashing

2.2 read the user card that needed on the induction coil, hear the sound of beep. (can input 2,000 pcs user cards continuously)

2.3 read the Management Card again, red indicator light is flashing, repeat again read the Management Card, green indicator light turn red, that meaning user card is successful input.

3. Delete user card

read the Management Card on the induction coil, green indicator light is flashing, repeat again read Management Card for 6 seconds, indicator light turn red, all the user cards are deleted.

A. The Function Operation of the infrared remote control

1. Amend the pass word of the Factory

1) Use the infrared remote control, input **[*] + [system original password] + [#]**, the indicator light turn red.

2) Input **[*] + [01] + [#]**, the indicator light turn the bicolor light.

3) Input **[*] + [new pass word] + [#]** to finish setting

4) Input **[*] + [new pass word] + [#]** again. If the input are not same as the first time, you will hear "BB" sounds for twice, that mean it is wrong. It will back to the step 3! If the same as the first time, You will hear the long bell, that mean the setting is successful for the amendment, and the indicator light will back the original status.

2. How to set the Management Card

1) Use the infrared ray control, input **[*] + [system pass word] + [#]**, the indicator light is on red

2) Input **[*] + [02] + [#]**, Meanwhile the light is off, and the system is in the setting status.

3) Input **[*] + [10 card number] + [#]**, or use the card reader to read other ID cards. If hear the bell, that's mean setting is successful. The system will exit the setting status automatically

3. How to set the door opening time

1) Use the infrared ray control, input **[*] + [system pass word] + [#]**,

2) Input **[*] + [03] + [#]**

3) Input **[*] + [number between 0 to 99] + [#]**. When it finish setting. The system will exit the setting status automatically,

4) Pay attention: The setting time is as long as 10 seconds, and the step-by step is 0.1 second.

4. Add the user card, pass word and wireless control

1) Use the infrared ray control, input **[*] + [system pass word] + [#]**

2) Input **[*] + [04] + [#]** If the indicator light is on green to the adding user status.

3) Input **[*] + [ID card number or user pass word] + [#]**, or use the ID card reader/315 wireless control. When hearing the prompt tone. That mean it is successful. Keep inputting other cards, pass words or controls. Repeat the step 3. You can input 2000 user at mot.

5. How to delete the user card

1) Use the infrared ray control, input **[*] + [system pass word] + [#]**

2) Input **[*] + [07] + [#]** The indicator light is on red to delete user status.

3) Input **[*] + [ID card number or pass word] + [#]**, or use the ID card reader/315 M wireless control. When hearing the prompt tone. That mean it delete successfully, and can delete other cards. Repeat the step 3, can continue deleting a number of card, pass words and 315M control.

6. How to delete the all user cards

- 1) Use the infrared ray control ,input **[*] + [system pass word] + [#]**
- 2) Input **[*] + [19] + [#]** .If the indicator light is red, mean that in the deleting all users status.
- 3)Input **[-]** ,exit the setting

B. How to use the management card?

1. Add user

- 1) swipe the management ID card, the indicator light will turn to green
- 2) swipe the user ID card, or input the user pass word with the infrared ray control/reader 315M control .While hearing the sound, that is successful to add user.
- 3) Repeat the step 2, can continue to input 2000 users.
- 4) If can not input the ID card in 15 seconds, the system will exit automatically, and back to the original holding status

2. How to delete the user.

- 1) Continue to swipe the management card for twice, the system will delete the user automatically, which the light is on red.
- 2) Put the user card which need to delete near the reader circle , or input **[*] + [user card or pass word] + [#]** ,or use the reader 315M control, it is successful to delete,while hearing the "B".
- 3) Repeat the step 2, can delete other users
- 4) If do not input any figure in 15 seconds, that will back to the holding status.

3. How to delete all users (wireless control and user pass word)

- 1) Continue to swipe the management card .When you swipe for the second time, the card will hold for 5 seconds, and the system will delete all card user, control user and pass word user.
- 2) It will back to the holding status, when it finish to delete.

C. Factory Default

- 1) Cut off the power,short circuit for 1 plug and 2 plug of the JP1 of the breadboard.
- 2) Turn on the power , when you hear message of about 2 seconds,that mean the recover is successful, and the pass word of system administration is **[9999]** , the delay time of unlocking will hold for 5 seconds.
- 3) Cut off the power, repeal the short circuit cap of JP1

Wiring diagram of the interphone

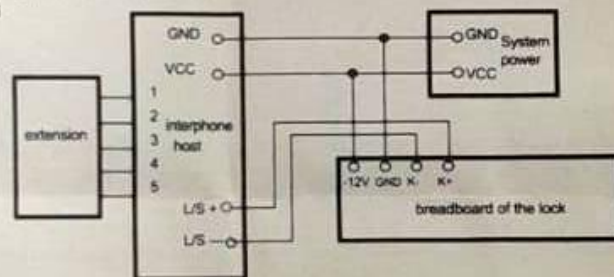

The form of common fault analysis:

fault phenomenon	cause	resolvent
pilot lamp of the lock unlit or no response	No power source	Check the power cord,switch-in the right power
Pilot lamp is light but no response when closed door	The distance between strike and lock body is over 5 mm	Change the distance less than 5 mm
no response when Unlock	Pick the wrong lock line	Adjust the method of unlock signal input ,it's often open, and a moment Lock voltage is 4 V-12 V, > 50 mS,differentiate "+" and "-"
Lock and unlock are not flexible	Transmission ruler of cylinder and door spindle of key turning in a different centre of the circle	1 Adjust the master lock body installation position,keep the key turn flexibility 2 Check are there anythings into the lock when install
Buzzer has been ring	The bolt is not in place	Close the door again,remove something that lock the bolt
Wireless remote control out of control		1 Check whether the battery of the remote controller is disabled, if it is, please change the new one 2 Check whether the built-in aerial of the lock is pulled out ,or put it out of the lock
Don't read the cards	the problem of card reader lap coil	check whether the card reader lap coil is fallen off
Buzzer is been ring,can't lock	the problem of motor	check whether the motor is fallen off or not fixed

Function:

1. With ID card or EM compatible cards reading card function,supporting wireless remote control and password.
2. With infrared remote control function,deleting,increasing,remote control opening function.
3. Supporting 2000 users
4. With function of independently delete,increase user card function
5. Infrared remote control function offers the damage caused by lost card,it is convenient that customer can change their user data.(customer must know the missing card number)
6. With function of prompting when lock body occur abnormal condition.
7. Support building system or other management system locking function

Attention:

1. To set state, if there is no new input within 15 seconds or press the key **[-]** of the infrared remote control,that will quit the set state.
2. the internal resistance is 4.7M Ω of the 315 MZ remote control our configuration,if you use other remote control,pay attention to the internal resistance of them.
3. Install lock,please put the internal remote antenna out of the lock,otherwise, it will cause the remote control invalid or cut down the remote distance
4. In the setting process,it will quit the set state,if press the key **[-]** of the infrared remote control.